

CURRERA-R Starter Kit Quick start guide

To start working with the Starter Kit you will also need:

- PC Display with standard Analog input
- PC Display Cable
- USB mouse
- USB keyboard

1 Mount CURRERA to the Tripod Adapter

Use four screws and hex key to attach CURRERA to the Tripod Adapter as shown on the right. You may prefer to connect the cables first as described in the step 3.

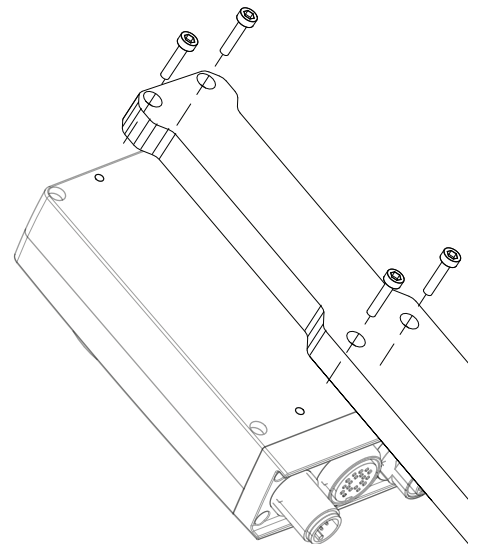

2 Attach Lens

Remove sensor cap first and attach lens using the supplied C/CS mount adapter.

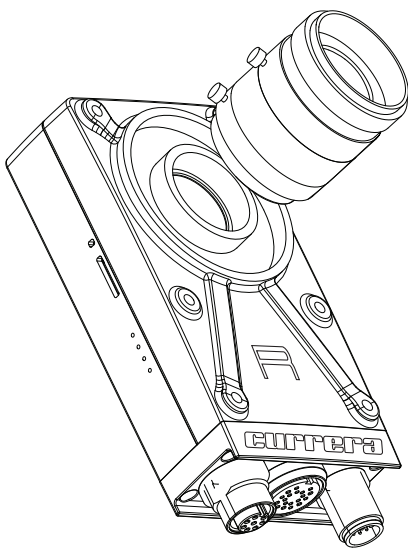

3 Connect cables

Connect System Cable to System Port (Middle one).
 Connect BOB144 to System Cable.
 Connect USB hub to USB port on BOB144.
 Connect USB mouse and USB keyboard to USB hub.
 Connect VGA adapter to Display port and connect your VGA monitor.
 Connect power supply to EXT PWR port which is connected to AUX on BOB144.

4 Power up

Plug power supply to the line. PWR OK led should light up and the boot shall proceed within few seconds.

5 Run the xVIEWER application

As soon as Windows desktop appears, you may start xviewer application located on desktop to see live image from camera.

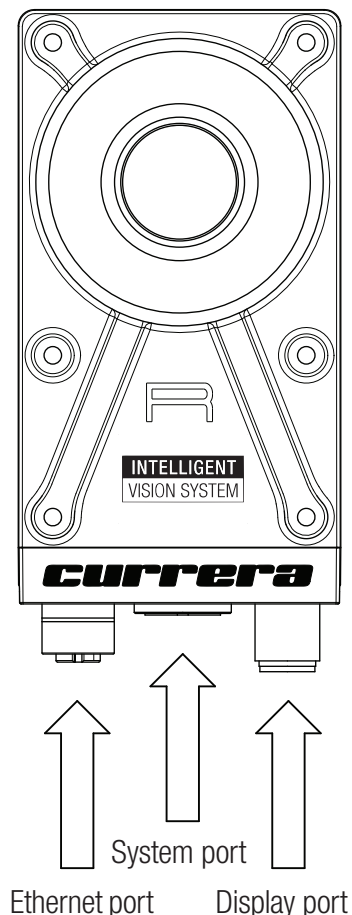

Packing list

- CURRERA-R RL13
- Lens FUJINON HF16HA-1B
- Desktop Tripod with Adapter
- Four M3 screws for CURRERA to Tripod Adapter mounting
- Hex Key
- 2m 1000M Ethernet cable (green)
- Display Cable adapter
- System cable
- BOB144 (breakout PCB)
- BOB144 description
- Power supply (24V / 1.25A)
- Getting started guide
- System Image Recovery USB Stick

Preinstalled software

- Windows embeded standard 2009
- Bonjour service
- Sensor drivers
- xiViewer
- Optional Vision Libraries Demos